

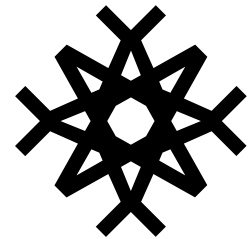

# WATER-POWERED DRILLING

## TECHNICAL SPECIFICATION: W280 HAMMER



Wassara

The Wassara technology uses water to power the DTH hammer. This makes it the ideal choice for drilling in sensitive areas as well as for drilling long straight holes. The water-powered hammer is capable of penetrating almost any formation while maintaining speed and accuracy.

Technical specifications – W280.210	
Length A	2 540 mm (100")
Length B	2 413 mm (95")
Diameter C	Ø 285 mm (11.2 ")
Size D 	240 mm (9.45")
Weight (excl. drill bit)	915 kg (2 017 lbs)
Casing outer diameter	406 – 508 mm (16" / 20")
Operating pressure max	50 – 150 bar (2175 psi)
Frequency at maximum operating pressure	30 Hz (1 800 blows/min)
Feed force, formation dependent	60 – 120 kN
Rotation speed, formation dependent	25 - 50 rpm
Water consumption interval	1 100 - 1 600 l/min
Drill rod	273x12,5 mm (11") Thread API 6 5/8 REG
Recommended water pump	2 pcs WASP200D 800 l/min (211 USgpm) @ 160 bar (2 320 psi)
Bit shank	Numa 125

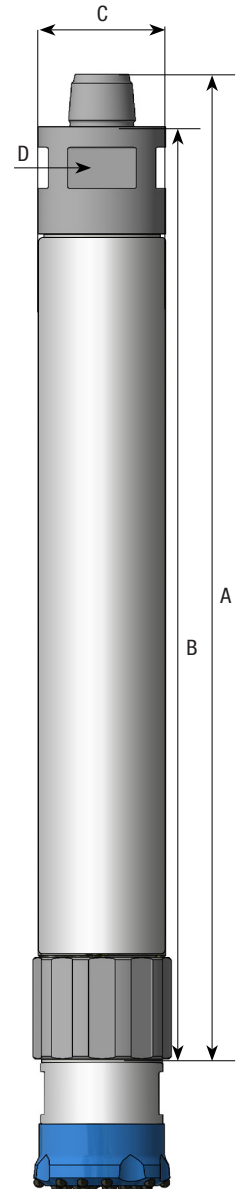

# PARTS LIST: W280.210

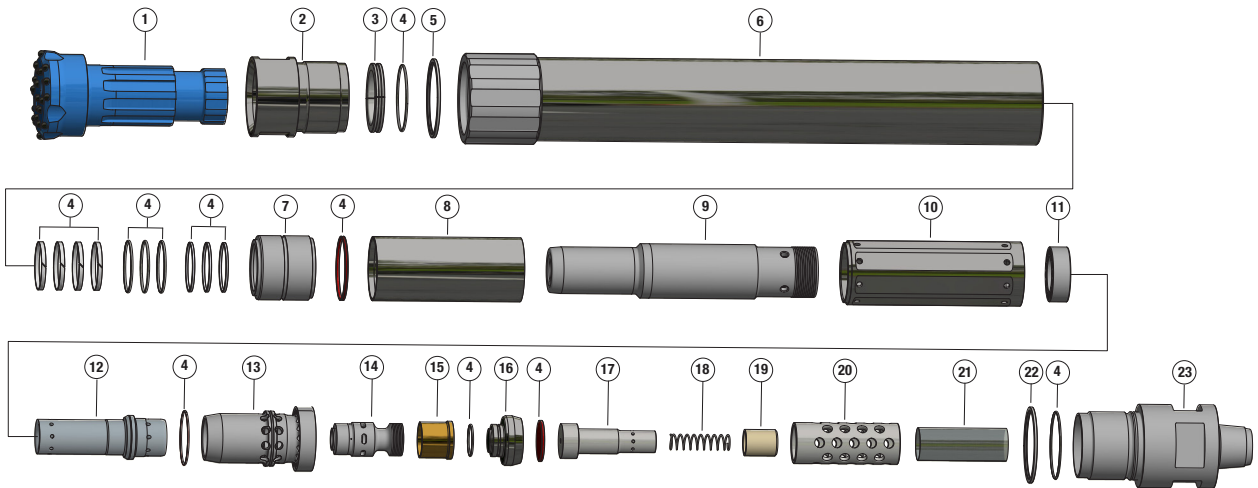

Pos	Detail	Part no
	<b>Hammer W280, Ø 285 mm</b>	1500590-285
<b>1</b>	Drill bit	Numa shaft
	Drive plates	1500543
	Chuck bushing	1003239
<b>2</b>	Chuck (incl. chuck bushing)	1500587
<b>3</b>	Bit retainer	1003499
<b>4</b>	Seal kit	1003190
<b>5</b>	Shims (chuck-end)	1501911
<b>6</b>	Hammer case	1501923
<b>7</b>	Piston bushing	1500584
<b>8</b>	Inner tube	1500581
<b>9</b>	Piston	1500588
<b>10</b>	House retainer	1501838
<b>11</b>	House retainer ring	1501839

Pos	Detail	Part no
<b>12</b>	Sliding case	1501216
<b>13</b>	Valve house	1500582
<b>14</b>	Valve	1500589
<b>15</b>	Sleeve	1501345
<b>16</b>	Lid	1500585
<b>17</b>	Check valve shutter guide	1501344
<b>18</b>	Check valve spring	1002624
<b>19</b>	Check valve shutter	1501343
<b>20</b>	Filter support	1500496
<b>21</b>	Filter	1500497
<b>22</b>	Shims (backhead-end)	1501910
<b>23</b>	Backhead 6 5/8 API Reg	1500499